

**Operating Instructions
for
Pressure Gauge Transmitter**

Model: MAN-ZF



1. Contents

1. Contents.....	2
2. Note	3
3. Instrument Inspection.....	3
4. Caution to Users	4
5. Mechanical Connection.....	4
6. Electrical Connection	5
7. Operation	6
8. Accuracy and Recalibration	7
9. Technical Information.....	8
10. Maintenance	8
11. Dimensions	9
12. Declaration of Conformance	10

Manufactured and sold by:

Kobold Messring GmbH
Nordring 22-24
D-65719 Hofheim
Tel.: +49(0)6192-2990
Fax: +49(0)6192-23398
E-Mail: info.de@kobold.com
Internet: www.kobold.com

2. Note

Please read and take note of these operating instructions before unpacking and commissioning. The instruments may only be used, maintained and installed by personnel familiar with the Operating Instructions and the applicable Health and Safety Requirements.

When used in machines, the measuring unit should be used only when the machines fulfil the EWG-machine guidelines.

as per PED 97/23/EG

In acc. with Article 3 Paragraph (3), "Sound Engineering Practice", of the PED 97/23/EC no CE mark.

	Pipe	
	Diagram 1 Group 1 dangerous fluids	Diagram 2 Group 2 no dangerous fluids
MAN, ≤ 200 bar	Art. 3, § 3	Art. 3, § 3
MAN, > 200 bar	Cat. I	Art. 3, § 3

3. Instrument Inspection

Instruments are inspected before shipping and sent out in perfect condition. Should damage to a device be visible, we recommend a thorough inspection of the delivery packaging. In case of damage, please inform your parcel service / forwarding agent immediately, since they are responsible for damages during transit.

Scope of delivery:

The standard delivery includes:

- Pressure Gauge Transmitter model: MAN-ZF
- Operating Instructions

4. Caution to Users

Pressure gauge/transmitters can be rendered inaccurate during shipment despite care taken in packaging. To ensure conformance to the published specification, it should be checked carefully before use.

5. Mechanical Connection

- Before installation check that the gauge/transmitter is suitable for the intended use range of measurement and the process connection.
- Ensure that when installed, the transmitter is not subjected to excessive humidity, corrosive gases and heat sources.
- Mechanical vibrations should also be avoided.
- The process connection must be properly sealed with material compatible with the process fluid/gas.
- During fitting care must be taken to ensure that the connector is tightened with an appropriate tool (spanner wrench) on the process fitting (lower hexagon "O"), provided for that purpose. Do not exert any force on the transmitter case. When installing transmitters with diaphragm seals tighten the seal/process connector, not the transmitter, otherwise transmitter/seal calibration can be affected.
- If the transmitter is mounted remotely with a capillary connection to the process measuring point ensure capillary is not twisted or kinked.

6. Electrical Connection



Attention! Make sure that the voltage values of your system correspond with the voltage values of the measuring unit.

Make sure that the supply wires are de-energized.

Attention! Incorrect wiring will lead to damage of the unit's electronics.

ZF 26A4 4...20mA 2-wire

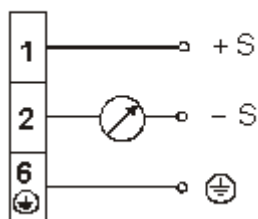

1 Power Supply: 24 V_{DC}

2 Signal Output: 4...20 mA

6 Ground

ZF 26A4 0...20mA 3-wire

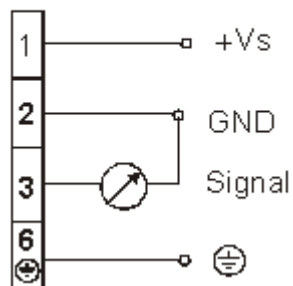

1 power supply: 24 V_{DC}

2 Mass

3 Signal Output: 0...20 mA

6 Ground

According to the unit version the connection parameters are indicated on the label of the transmitter.

7. Operation

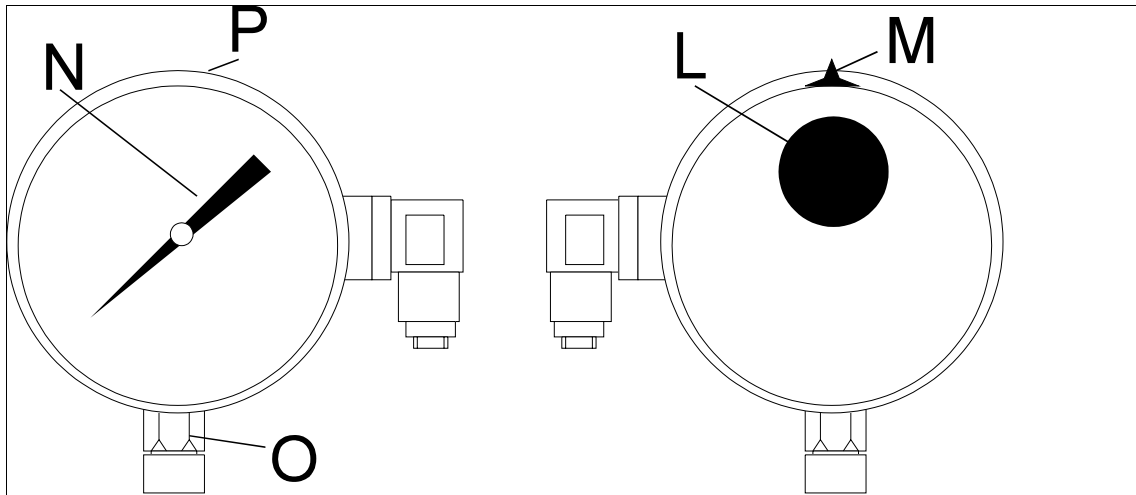

It is important to ensure that operating parameters do not exceed the original specification stated at time of purchase.

In particular, check:

- No pressures occur that exceed the specified over-pressure limit of the transmitter.
- Steady pressures do not become pulsating.
- Mechanical vibrations do not become excessive.
- Apply system pressure slowly to avoid start-up peaks or surges.
- Check that fitting/assembly has been correctly carried out and there are no leakages.
- Process temperature should not exceed 60 °C. Where this occurs a suitable siphon or capillary (1.5-2 meters) must be installed which will reduce the process temperature to an acceptable level.



Warning! A very important aspect of selecting pressure gauges is the consideration of the hazards that will result in the event of gauge failure. The primary causes of failure are misapplication and/or abuse of the gauge. Those who are responsible for the selection and installation of pressure gauges must recognise conditions which will adversely affect the ability of the gauge to perform its function or which will lead to early failure. These conditions may then be discussed with the manufacturer to obtain his recommendations.

When installing a pressure gauge/transmitter the following factors must also be given attention:

Venting of case:

Vents provided in the pressure gauge case (rubber blow out "L" and filling plug "M") must not be closed or restricted from operating. There is always the possibility that the pressure medium will be admitted to the case interior because of leaking joints or bourdon tube failure. If this occurs, the pressure medium must be vented from the case in order to avoid pressure build-up which may rupture the case or window. However, venting will not prevent case rupture in the event of a major tube/joint failure.

Liquid filled gauge:

Performance of pressure gauges used in severe vibration or pulsating pressure, can be improved by filling the gauge case with a viscous fluid. Gauges constructed in this manner necessarily require sealed cases to prevent the escape of the liquid. However, some means of venting the case must be provided. In some instances, the vent at the top of the gauge must be cut for this purpose. The filling liquid generally used is white oil. This can react with strong oxidizing agents such as (but non limited to) chlorine, nitric acid and hydrogen peroxide, and result in an explosion, which can cause damage and personal injury. If gauges are to be used in such service, do not use white oil filled gauges; consult the factory for correct filling medium.

8. Accuracy and Recalibration

- Calibration is carried out in the factory. It cannot be carried out by the client.

Any unauthorised adjustment or tampering with the electronic circuitry or mechanical parts inside the pressure gauge transmitter will render the manufacturers guarantee null and void.

9. Technical Information

Nominal size:	100
Accuracy class:	1.0 acc. to DIN EN 837-1 oil filling
Indicating range:	0...1 bar to 0...600 bar
Using	
by static pressure:	100% of f. s.
by dynamic pressure:	90% of f. s.
Housing:	stainless steel
Pressure connection:	G1/2 male bottom
Ring:	stainless steel
Window:	safety glass
Dial:	aluminium, white, scale black
Pointer:	aluminium
Cable connection:	cable plug
Supply	13-30 V _{DC} (standard version*)
Output signal	4- 20 mA, 2 wire (standard version)
Max. temperatures:	60 °C (medium) 60 °C (ambient) (7) filled version
Protection:	IP 54, with filling IP 65

*Special version: see unit label

10. Maintenance

In case that the medium which is to be measured is not contaminated, the measuring unit will be maintenance-free.

11. Dimensions

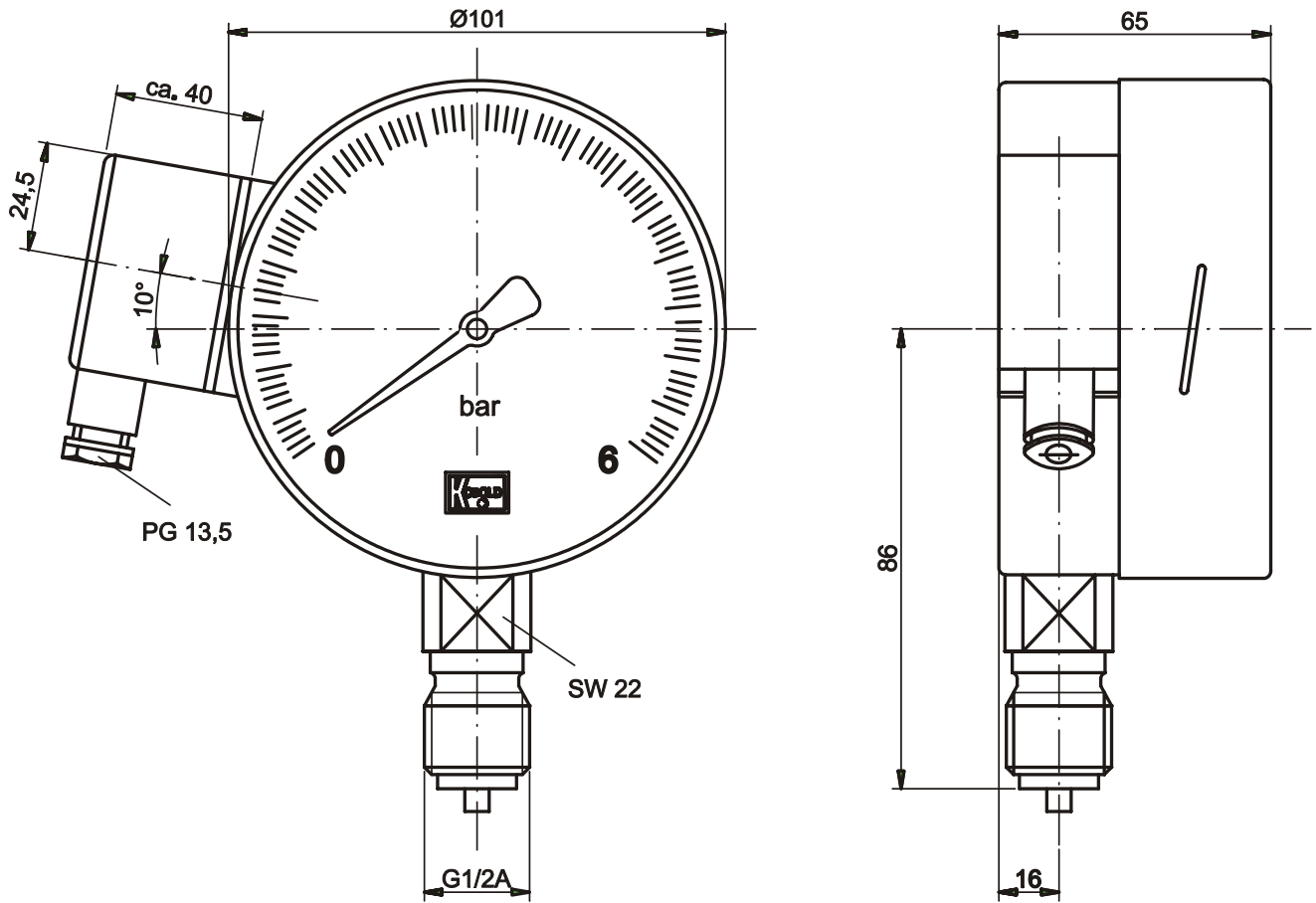

12. Declaration of Conformance

We, Kobold-Messring GmbH, Hofheim-Ts., Germany, declare under our sole responsibility that the product

Pressure Gauge Transmitter Model MAN-ZF...

to which this declaration relates is in conformity with the standards noted below:

EN 50081-1, EN 50081-2

Electromagnetic compatibility - Fundamental Discipline / Standard Noise

EN 50082-1, EN 50082-2

Electromagnetic compatibility - Fundamental Discipline / Standard Noise Stability

Also the following EWG guidelines are fulfilled:

2004/108/EC EMC Directive

for MAN, > 200 bar

97/23/EG PED

Category I, Diagram 1,
Group 1 dangerous fluids
Module D, mark CE0098
notified body: Germanischer Lloyd Germany

Hofheim, 16. Jan. 2007



H. Peters
General Manager



M. Wenzel
Proxy Holder