

Deflection Paddle Flow Transmitter for Liquids



measuring
•
monitoring
•
analyzing

DWD



- Measuring Ranges: 0.26...2.6 GPM to 1585...15850 GPM Water
- Measurement Accuracy: $\pm 1.5\%$ f.s.
- Connection: $\frac{3}{8}$ "...2" NPT, G $\frac{3}{8}$ "...G 2
Flange: ANSI $\frac{3}{8}$ "...2",
DN 10...DN 50
Weld-on for Pipe Sizes:
1.5"...20", DN 40 ... DN 500
- Wetted Material: Brass/St. Steel, SS/SS
- p_{\max} : 360 PSIG
- t_{\max} : 250 °F
- Universal Mounting



KOBOLD companies worldwide:

ARGENTINA, AUSTRALIA, AUSTRIA, BELGIUM, BULGARIA, CANADA, CHILE, CHINA, COLOMBIA, CZECH REPUBLIC, EGYPT, FRANCE, GERMANY, HUNGARY, INDIA, INDONESIA, ITALY, MALAYSIA, MEXICO, NETHERLANDS, PERU, POLAND, REPUBLIC OF KOREA, ROMANIA, SINGAPORE, SPAIN, SWITZERLAND, TAIWAN, THAILAND, TUNISIA, TURKEY, UNITED KINGDOM, USA, VIETNAM

KOBOLD Instruments, Inc.
1801 Parkway View Drive
Pittsburgh, PA 15205
Main Office:
1.800.998.1020
1.412.788.4890
info@koboldusa.com
www.koboldusa.com



Description

The DWD is a flow transmitter with digital rate indication, analog output and two adjustable relays for monitoring flow rate values with an optional RS-232C serial interface. The proven paddle displacement-deflection measuring technique and a patented pendulum system with integral display electronics combine to provide a reliable and more economical option to alternate methods of measurement. The flowing media presses against a paddle that is fastened to a pendulum, causing displacement of the paddle. The pendulum, retained by a progressive spring system, changes its position based upon the actual flow rate. A magnet attached to the pendulum is detected by a Hall-effect sensor which is completely isolated from contact with the media. The signal is evaluated by microchip-based electronics with EEPROM memory. The DWD measuring range is factory configured according to the requested specifications and is supplied ready for operation once installed. The display is supplied oriented appropriately for the requested mounting position. Due to a wide variety of standard material combinations and process connections, the DWD can handle many applications including flow measurement in large line diameters.



Design Advantages:

- Reliable and Economical
- Immediately Ready for Operation
- No Bearings, No Friction
- Insensitive to Dirt
- Wide Flow Range
- Small Pressure Loss

Technical Details

Flow Range: Flow Ratio 1:10
(Example: 2.64...26.4 GPM)

Accuracy: ± 1.5 % f.s.

Media Temperature: -4 ... 250°F

Max. Pressure: 360 PSIG

Direction of Flow: Specified Upon Ordering

Analog Output: 4 ... 20 mA or 0 ... 10 V, User Selectable

Switching Contacts: 2 x 230 V, 1 A Max, User Adjustable

Display: LCD DOT-matrix, 2 x 8 Positions

Totalizer: Values Retained in EEPROM Memory

Power Supply: 24 VDC ±10%

Current Consumption: Max. 200 mA

Protection Type: IP 65

Option: RS-232C Serial Interface

Device Part	Material Combination	
	5	6
Pendulum Case	Brass	Stainless Steel
Pendulum System	Stainless Steel	Stainless Steel
T-Piece	Brass	Stainless Steel
Seals	FKM	FKM
Connecting Thread	Brass	Stainless Steel
Connecting Flange	Zinc-plated Steel	Stainless Steel
Weld-on Part	Stainless Steel	Stainless Steel
Electronics Housing	Painted Aluminum and Polyamide	Painted Aluminum and Polyamide
t _{max}	250 °F	250 °F
p _{max}	360 PSIG	360 PSIG

Deflection Paddle Flow Transmitter Model DWD



Flow Transmitter with Threaded Connection

Min. Flow Range (GPM Water)*	Max. Flow Range (GPM Water)*	Body Material: Pendulum System/T-Piece		Process Connection Threaded **	Power Supply	Flow Direction - Indicator Location	Option
		SS/Brass	SS/SS				
0.26	6.6	DWD-55..	DWD-56..	..R10.. = G 3/8 ..N10.. = 3/8" NPT	..3.. = 24 V _{DC}	..RT.. = Right to Left, Indicator Above Pipe ..LT.. = Left to Right, Indicator Above Pipe ..TL.. = Top to Bottom, Indicator Left of Pipe ..BL.. = Bottom to Top, Indicator Left of Pipe ..TR.. = Top to Bottom, Indicator Right of Pipe ..BR.. = Bottom to Top, Indicator Right of Pipe	..0 = Without ..7 = RS-232C Interface
0.26	14.5	DWD-55..	DWD-56..	..R15.. = G 1/2 ..N15.. = 1/2" NPT			
1.32	26.4	DWD-55..	DWD-56..	..R20.. = G 3/4 ..N20.. = 3/4" NPT			
1.58	39.6	DWD-55..	DWD-56..	..R25.. = G 1 ..N25.. = 1" NPT			
2.64	66	DWD-55..	DWD-56..	..R32.. = G 1-1/4 ..N32.. = 1-1/4" NPT			
5.28	105	DWD-55..	DWD-56..	..R40.. = G 1-1/2 ..N40.. = 1-1/2" NPT			
13.2	158	DWD-55..	DWD-56..	..R50.. = G 2 ..N50.. = 2" NPT			

** Model DWD-55... Female thread up to conn. size: R40/N40, above: male thread; Model DWD-56... Female thread up to conn. size: R20/N20, above: male thread

Flow Transmitter with Flanged Connection

Min. Flow Range (GPM Water)*	Max. Flow Range (GPM Water)*	Body Material: Pendulum System/T-Piece		Process Connection Flanged	Power Supply	Flow Direction - Indicator Location	Option
		SS/Brass	SS/SS				
0.26	6.6	DWD-65..	DWD-66..	..F10.. = DN 10 ..A10.. = 3/8" ANSI	..3.. = 24 V _{DC}	..RT.. = Right to Left, Indicator Above Pipe ..LT.. = Left to Right, Indicator Above Pipe ..TL.. = Top to Bottom, Indicator Left of Pipe ..BL.. = Bottom to Top, Indicator Left of Pipe ..TR.. = Top to Bottom, Indicator Right of Pipe ..BR.. = Bottom to Top, Indicator Right of Pipe	..0 = Without ..7 = RS-232C Interface
0.26	14.5	DWD-65..	DWD-66..	..F15.. = DN 15 ..A15.. = 1/2" ANSI			
1.32	26.4	DWD-65..	DWD-66..	..F20.. = DN 20 ..A20.. = 3/4" ANSI			
1.58	39.6	DWD-65..	DWD-66..	..F25.. = DN 25 ..A25.. = 1" ANSI			
2.64	66	DWD-65..	DWD-66..	..F32.. = DN 32 ..A32.. = 1-1/4" ANSI			
5.28	105	DWD-65..	DWD-66..	..F40.. = DN 40 ..A40.. = 1-1/2" ANSI			
13.2	158	DWD-65..	DWD-66..	..F50.. = DN 50 ..A50.. = 2" ANSI			

Flow Transmitter with Weld-on Connection

Min. Flow Range (GPM Water)*	Max. Flow Range (GPM Water)*	Body Material: Pendulum System/Weld-on part		Nominal Pipe Diameter	Power Supply	Flow Direction - Indicator Location	Option
		SS/SS	SS/SS				
5.28	105	DWD-75..	DWD-76..	..W40 = 1.5"	..3.. = 24 V _{DC}	..RT.. = Right to Left, Indicator Above Pipe ..LT.. = Left to Right, Indicator Above Pipe ..TL.. = Top to Bottom, Indicator Left of Pipe ..BL.. = Bottom to Top, Indicator Left of Pipe ..TR.. = Top to Bottom, Indicator Right of Pipe ..BR.. = Bottom to Top, Indicator Right of Pipe	..0 = Without ..7 = RS-232C Interface
13.2	158	DWD-75..	DWD-76..	..W50 = 2"			
21.1	264	DWD-75..	DWD-76..	..W65 = 2.5"			
31.7	396	DWD-75..	DWD-76..	..W80 = 3"			
52.8	634	DWD-75..	DWD-76..	..W1H = 4"			
79.3	990	DWD-75..	DWD-76..	..W1Z = 5"			
106	1452	DWD-75..	DWD-76..	..W1F = 6"			
185	2640	DWD-75..	DWD-76..	..W2H = 8"			
317	3962	DWD-75..	DWD-76..	..W2F = 10"			
450	5283	DWD-75..	DWD-76..	..W3H = 12"			
660	7925	DWD-75..	DWD-76..	..W3F = 14"			
792	10566	DWD-75..	DWD-76..	..W4H = 16"			
1321	15850	DWD-75..	DWD-76..	..W5H = 20"			

* NOTE: When ordering please also supply the following: media type, media viscosity, operating temperature and pressure, and desired flow range within the min/max flow range values stated above with the ratio of min/max 1:10. For example order code DWD-55... can provide a 1:10 ratio range from 0.26...2.6 to 0.66...6.6 (or anything in between with a 1:10 ratio such as 0.34...3.4 or 0.52...5.2)

Dimensions

DWD-55.. to 1½" with Female Thread

DWD-56.. to ¾" with Female Thread

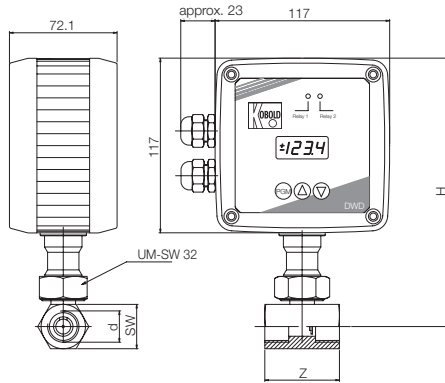

NW	L (mm)	H (mm)
3/8"	50	180 (180)
1/2"	50	180 (180)
3/4"	50	180 (180)
1"	50	185
1-1/4"	50	190
1-1/2"	50	194

Values in () valid for DWD-56..

DWD-55.. 2" with Male Thread

DWD-56.. from 1" with Male Thread

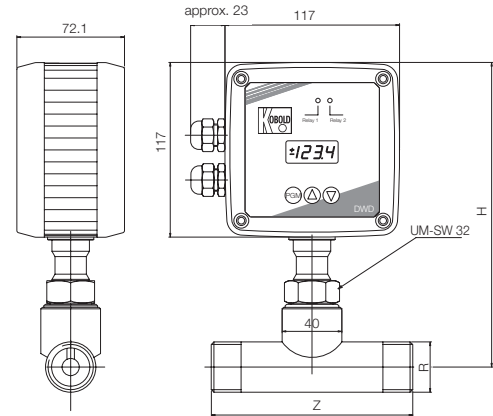

NW	L (mm)	H (mm)
1"	135	(201)
1-1/4"	170	(201)
1-1/2"	170	(201)
2"	170	202 (211)

Values in () valid for DWD-56..

DWD-65/66.. with Flange

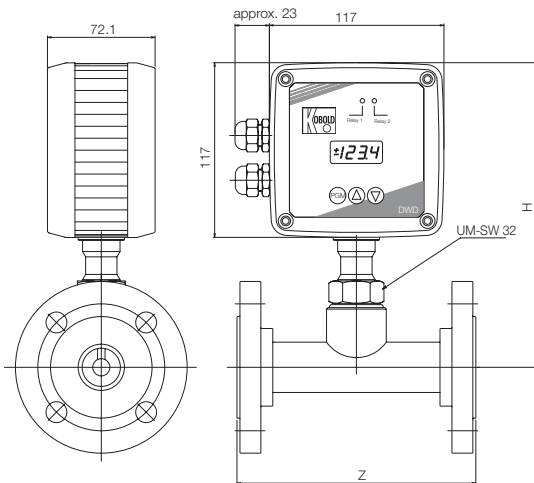

DN	D (mm)	K (mm)	L (mm)	H (mm)
10	90	60	155	180 (180)
15	95	65	155	180 (180)
20	105	75	160	180 (180)
25	115	85	160	185 (201)
32	140	100	190	190 (201)
40	150	110	190	194 (201)
50	165	125	190	202 (211)

Values in () valid for DWD-66..

DWD-7.. with Weld-on Connection

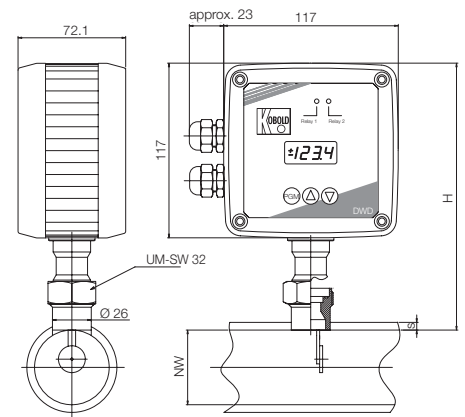

NW	H (mm)
from DN 40	180